



RAINWATER HARVESTING

WFF150 VORTEX FILTERS

- Connects to standard storm water pipes below ground
- Can also be wall-mounted
- Virtually all debris, moss, leaves, insects, etc. is washed through the uniquely constructed vertical filter by self-cleaning action
- No restriction or obstruction of water flow through the appliance (conforms to DIN1986)
- More than 90% efficient
- Minimum maintenance
- Tough polyethylene housing
- High quality stainless steel filter mesh
- 50cm extension tube can be trimmed to length to suit invert level

WFF filters can be used where rainwater from the roof is channelled through a horizontal underground pipe.

The unit filters and diverts rainwater to a storage tank or cistern. Leaves and other large debris are washed through to a drain or soakaway.

Rainwater enters the inlet connection in the side of the WFF. The inlet is designed to swirl the water in a vortex-like action around the surface of the stainless steel filter below. The rainwater is drawn through the vertical mesh walls of the fine filter by adhesion, then collected and fed through the outlet to the storage tank. Debris and particles too large for the filter are flushed through to the drain outlet by the action of water flowing down the surface of the filter. More than 90% of the rainwater entering the WFF is filtered and collected by this principle.

There are no restrictions or obstructions on which debris can collect. The full cross-section of the rainwater drainage system is maintained right through the filter, so that excess rainwater is led directly to the storm drains or soakaway. This is especially important in hail storms and torrential rainfall. Even in such extreme cases much of the filtered water is transferred to the storage tank.

For roof areas greater than 500m² more than one filter unit can be used. For roof areas up to 3000m² a larger industrial filter unit, the WFF300 with a mesh size of 0.38mm, is also available to order (see separate data sheet).



WFF150 vortex filter with extension tube

The filter insert is virtually self-cleaning by the action of water flowing over the vertical mesh.

Pitched roofs of slate, clay or concrete are the most suitable for collecting rainwater. Flat roofs can also be utilised but the volume of water collected is reduced. Planted roof areas or thatch are less suitable due to the low collection efficiency and discolouration of the collected water.

WFF vortex filters are available in two mesh sizes. The 0.44mm version provides water clean enough for garden irrigation and car washing, etc. For finer filtration, (e.g. WCs, laundry use etc.) a 0.28mm version is available. The filter element does not need to be replaced, but must be kept clean for efficient operation. This normally requires cleaning only at 2-3 month intervals but in certain situations may require cleaning more frequently.

ATV tested - carries vehicles of up to **30t**
Rated according to DIN 1072/SLW 30



WISY WFF150 VORTEX FILTER

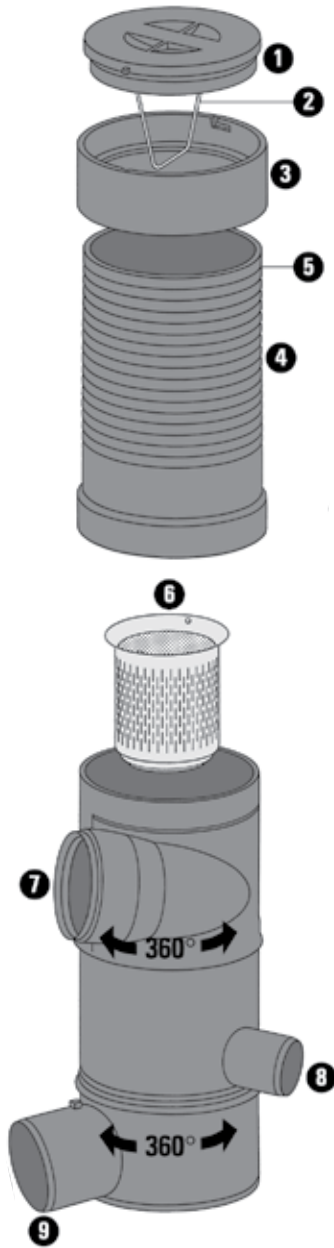

WFF filter components

- 1 - Lid
- 2 - Filter removal handle
- 3 - Upper ring
- 4 - Extension tube
- 5 - Parallel cutting lines
- 6 - Filter insert
- 7 - Rainwater inlet
- 8 - Clean water outlet
- 9 - drain outlet

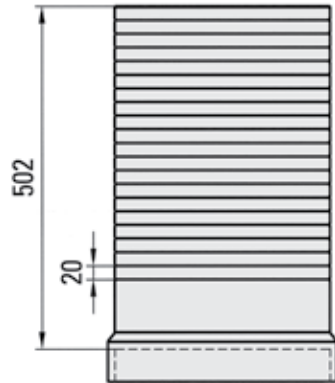
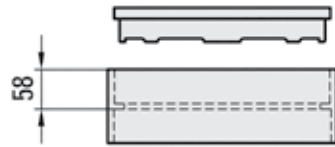

the extension tube supplied with each filter can be trimmed (or omitted altogether) to suit the finished ground level.

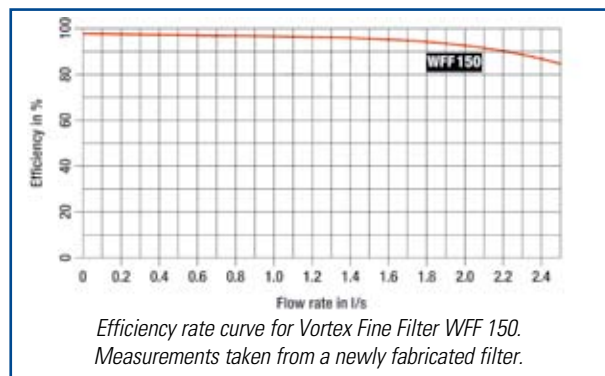
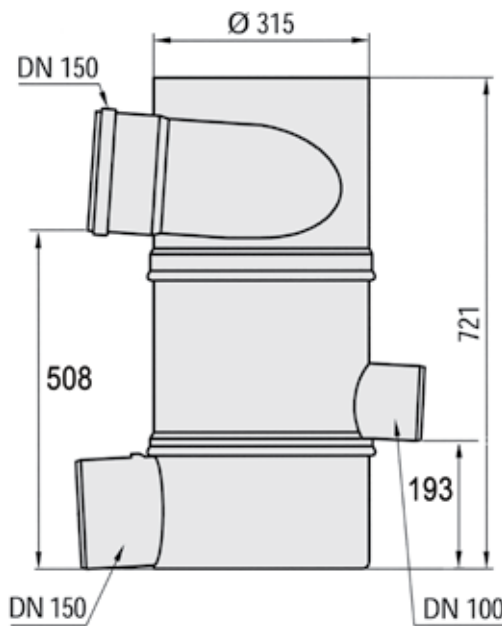

The WFF-150 unit:
 Polypropylene housing
 Stainless steel filter insert
 Rainwater inlet DN 150 (160mm pipe)
 Storage tank outlet DN 100 (110mm pipe)

Drain outlet DN 150 (160mm pipe)
 All connections can rotate through 360°
 0.44mm or 0.28 mm mesh versions
 Supplied with 50cm extension tube

WFF FILTER ACCESSORIES

50cm extension tube

For installations where the filter connects to a deep storm drain additional extension tubes are available. Easily cut to length due to the moulded in parallel lines.

Extended filter handles

For use where one or more full length extension tubes are used. The longer handles enable easy removal of the filter insert for cleaning purposes. Available in 63cm and 100cm lengths.

Stainless-steel wall bracket

For mounting the unit to a wall, where the filter is used internally or is supplying an above-ground tank

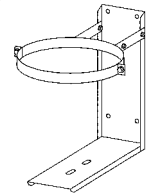

Stainless-steel strainer basket

Fits inside the WFF filter to prevent debris from passing to waste. Requires regular inspection to empty the contents.

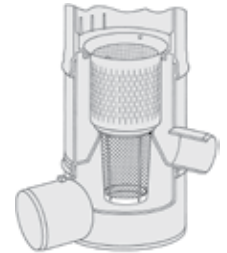

Blind Insert

For system maintenance purposes, a blind insert is available for both types. This can be used in place of the filter insert to divert all flow to the soakaway.

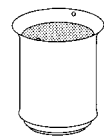

Paving can be laid around the end ring. The lid simply twists to remove.

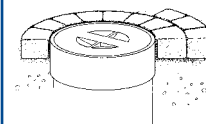

NB continuous development may necessitate change in these details without notice E&OE

Rainharvesting Systems Ltd.

The Green Shop
 Cheltenham Road, Bisley,
 Stroud, Gloucestershire GL6 7BX
 Tel: 0845 223 5430
 Fax: 01452 772008
 E-mail: sales@rainharvesting.co.uk
 Website: www.rainharvesting.co.uk

Distributor:

