



RAINWATER HARVESTING

VORTEX FINE FILTER WFF300

- Designed for industrial and commercial installations
- Suitable for roof areas up to 3,000m²
- Full cross-section of the drainage pipe is maintained right through the filter
- More than 90% efficiency at peak capacity of over 16 litres/sec.
- Low maintenance
- Stainless steel mesh 0.38mm
- Inlet and outlet rotate through 360°
- Corrosion and frost proof
- Tough polyethylene construction - withstands vehicle weights up to 60 tonnes gvw
- Extension tubes can be added to suit invert level
- Stainless steel base plate for long life and stability
- Connects to standard drainage pipe sizes



*ATV tested -
carries vehicles
of up to **60t**
conforms to DIN1072/SLW60*

PROVIDES CLEAN RAINWATER FOR INDUSTRIAL AND COMMERCIAL APPLICATIONS - SUITABLE FOR ROOF AREAS UP TO 3,000m²

WFF filters can be used where rainwater from the roof is channelled through a horizontal underground pipe. The WFF filters and diverts rainwater to a storage tank or cistern. Leaves and other large debris are washed through to a drain or soakaway.

Rainwater enters the inlet connection in the side of the WFF. The inlet is designed to swirl the water in a vortex-like action around the surface of the stainless steel filter below. The rainwater is drawn through the vertical mesh walls of the fine filter by adhesion, then collected and fed through the outlet to the storage tank. Debris and particles too large for the filter (particles greater than 380 microns)

are flushed through to the drain outlet by the action of water flowing down the surface of the filter. More than 90% of the rainwater entering the WFF is filtered and collected by this principle.

There are no restrictions or obstructions on which debris can collect. The full cross-section of the rainwater drainage system is maintained throughout the filter so that excess rainwater is led directly to the storm drains or soakaway. This is especially important in hail storms and torrential rainfall. Even in such extreme cases much of the filtered water is transferred to the storage tank.



The filter insert is virtually self-cleaning by the action of water flowing over the vertical mesh. Pitched roofs of slate, clay or concrete are the most suitable for collecting rainwater. Flat roofs can also be utilised but the volume of water collected is reduced. Planted roof areas or thatch are less suitable due to the low collection efficiency and discolouration of the collected water.

TECHNICAL DATA

Drained area: 3000 sq.m.
 Filter capacity: 16 litres/second
 Housing: Polypropylene
 Seals: Rubber
 Filter insert & mesh: Stainless-steel 1.4301
 Filter mesh size: 0.38 mm
 Rainwater inlet: DN 300*
 Tank outlet: DN 200*
 Drain outlet: DN 300*
 Lifting handle: Stainless-steel 1.4301
 Weight: 95 kg
 Cover load: Carries vehicles of up to 60t, (tested to DIN1072/SLW60)

Acid-resistant: Yes
 Groundwater neutral: Yes
 * DN = Nominal internal diameter of pipe.

An operating efficiency of 90% is maintained up to 16 litres/sec. - reduced efficiency at higher flows.

WFF300 FILTER ACCESSORIES

Extension tube

For installations where the filter needs to be deeper in the ground an extension tube is available. These are made to order, and can be up to a maximum of 1.4m long. An additional joining ring is also necessary when using an extension piece.

Filter handle extensions

For use where an extension tube makes the filter insert inaccessible from ground level. The extensions lengthen the normal 50cm handle and enable easy removal of the filter insert for cleaning purposes. Available in 50cm and 100cm lengths.



1. Heavy duty stainless steel cover
2. Stainless steel filter element
3. Locating ring for lid or extension tube
4. DN300 rainwater inlet
5. DN200 filtered water outlet

6. DN300 waste water outlet
7. Stainless steel baseplate
8. Lifting handle
9. Extension tube (accessory)

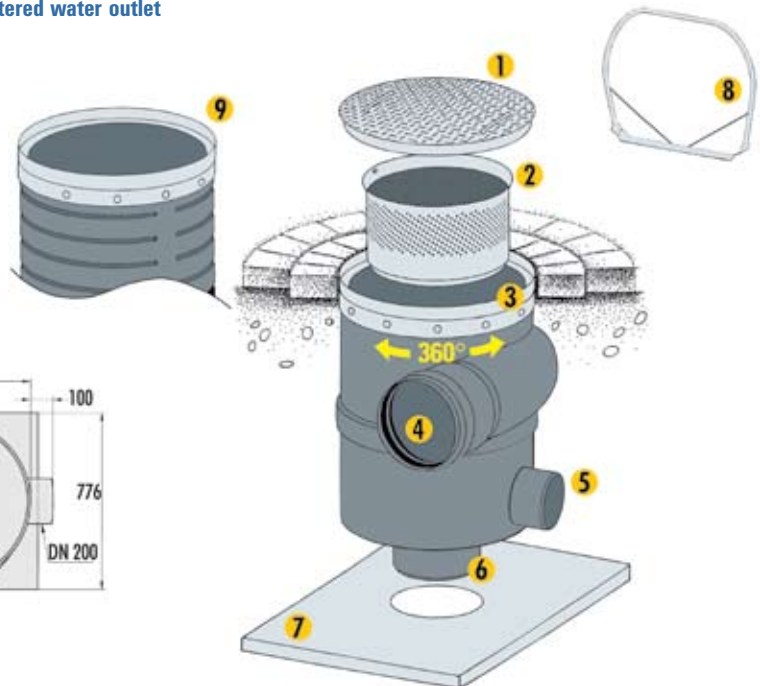
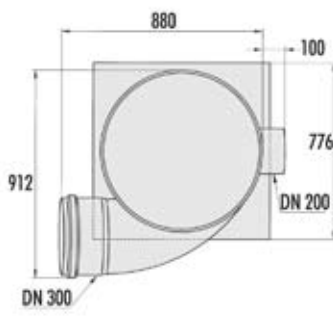
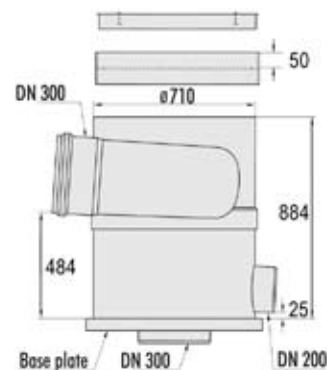

NB continuous development may necessitate change in these details without notice E&OE



Rainharvesting Systems Ltd.
 The Green Shop
 Cheltenham Road, Bisley,
 Stroud, Gloucestershire GL6 7BX
 Tel: 0845 223 5430
 Fax: 01452 772008
 E-mail: sales@rainharvesting.co.uk
 Website: www.rainharvesting.co.uk

Distributor: